

CRIMPING MACHINE EPS 2001 WITH SLIDE TABLE FOR AIRBAG CONNECTORS

PRODUCTION OF CABLES FOR AUTOMOTIVE INDUSTRY

High precision wire processing

The machine is designed for stripping and crimping of two single wires or two-core cables to terminals for Airbag systems.

The operator inserts the terminals and wires to be processed into a specific mold and the crimping process is started automatically after the sliding table has been pushed in. The robust machine design enables high durability and reproducibility of the crimp connections.

The modular structure of the automatic crimping machine stands for short set-up times and numerous expansion options.

Wide range of use options

A high degree of flexibility and diverse applications are made possible by the simple changeover to another product to be processed.

For crimping different terminals, crimp applicators can be easily exchanged using the quick-change device.

The ideal speed for the crimping process can be individually adjusted according to the existing terminal properties.

Quality assurance options

The integrated crimp force monitoring reliably detects false crimps during the production.

To support quality assurance, the products are verified with a barcode scanner and sensors are used to check availability in the mold.

Faulty cables are cut with the bad part cutter, thus preventing them from being used in downstream processes.

Modern operating interface

The touch screen control has an intuitive user interface for easy and safe operation of the crimping press in various languages.

Selecting different user roles and operating modes as well as machine networking functions provides flexible and modern process sequences.

PRODUCTION OF CABLES FOR AUTOMOTIVE INDUSTRY

High safety for the operator

The safety of the operator during processing of the crimping machine is ensured by a monitored safety device. Removal of protective covers interrupts the electrical safety circuit and the machine is stopped. For safe test operation after changeover and after maintenance work, the machine is equipped with the proven handwheel.

Conform with the machinery directive

The crimping machine for production of high quality connections fully complies with the European directives regarding mechanical and electrical safety as well as electromagnetic compatibility.

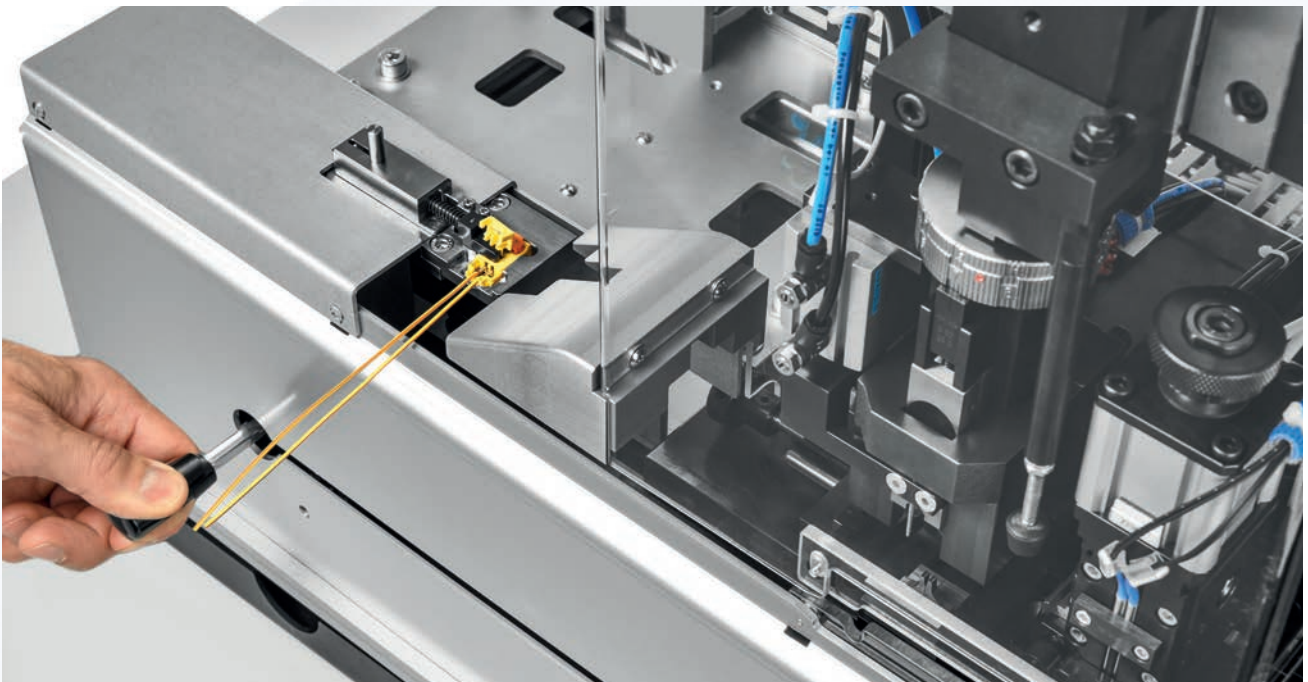

Base equipment

- Sliding table
- Machine cover
- Zero cut module
- Stripe chopper
- Crimp force monitoring
- Trash box

Optional extensions

- Crimping applicator
- Specific mold for table
- Specific stripping blades
- Specific wire gripper
- Vacuum cleaner
- Barcode scanner
- Bad part cutter
- Color sensor
- Foot switch
- Networking module
- Remote service module

TECHNICAL DATA

Processable materials

Wire	Two single wires or two-core cables
	Wire cross section: [1]
	2x 0.35 mm ²
	2x 0.50 mm ²
Terminals	Airbag system connectors

Performance and geometry

Drive	0.75 kW three-phase motor
Motor speed	440 – 2000 RPM
Pressing force	20 kN
Stroke	40 mm
Closing height	135.78 mm

Controls

Software	STI 2015
Display	Touchscreen

Supplies and interfaces

Power supply	230 V, 50/60 Hz
Compressed air	6 bar
Network	RJ-45

Dimensions and weight

Width x Depth x Height	800 x 900 x 550 mm [2]
Weight	145 kg [2]

[1] Depending on the configuration of wire and terminal.

[2] Approximate indication for basic equipment.



BRANCHES WORLDWIDE

GERMANY

Schäfer Werkzeug- und Sondermaschinenbau GmbH

Dr.-Alfred-Weckesser-Straße 6
76669 Bad Schönborn
Germany
Phone: +49 7253 9421 0
Fax: +49 7253 9421 94
E-Mail: info@schaefer.biz

Schäfer GmbH, Werkzeug- und Sondermaschinenbau

Industriegebiet Auf der Aue 1
99834 Gerstungen
Germany
Phone: +49 36927 9520
Fax: +49 36927 90478
E-Mail: unterellen@schaefer.biz

U. Kolb Werkzeug-Vertriebsgesellschaft mbH

Neuer Weg 32
71111 Waldenbuch
Germany
Phone: +49 7157 / 27585
Fax: +49 7157 / 72901
E-Mail: info@u-kolb-gmbh.de

USA

Schaefer Technologies LLC

751 N. Raddant Road
Batavia, IL 60510
USA
Phone: +1 630 406 9377
Fax: +1 630 406 9381
E-Mail: batavia@schaefer.biz

Schaefer Megomat USA Inc.

2349 S. Commerce Drive,
New Berlin, WI 53151
USA
Telefon: +1 262 524 1100
Fax: +1 262 524 1133
E-Mail: newberlin@schaefer.biz

Schaefer Megomat USA Inc.

10767 Gateway Blvd. West, Suite 510
El Paso, TX 79935
USA
Phone: +1 915 598 3037
Fax: +1 915 598 5374
E-Mail: elpaso@schaefer.biz

TUNESIA

Schaefer Tunisie SARL

Cité Echabeb, Avenue Essalem 18
4061 Sousse
Tunisia
Phone: +216 73 334 644
Fax: +216 73 334 645
E-Mail: sousse@schaefer.biz

ROMANIA

Schaefer Romania SRL

62 Petru Rares Str.
2900 Arad
Romania
Phone: +40 263 20 6021
Fax: +40 263 20 6021
E-Mail: arad@schaefer.biz

SWITZERLAND

Schäfer Megomat AG

Chollerstrasse 23
6312 Steinhausen
Switzerland
Phone: +41 41 748 58 00
Fax: +41 41 748 58 01
E-Mail: zug@schaefer.biz

POLAND

Schäfer Werkzeug- und Sondermaschinenbau GmbH

ul. ks. Bednorza 2a-6
40-384 Katowice
Poland
Phone: +48 32 608 1148
Fax: +48 32 608 1149
E-Mail: katowice@schaefer.biz

CHINA

Schaefer Trading (Shanghai) Co., Ltd.

Room 103, Building A
No. 355, Guang Zhong Road
Ming Hang District
Shanghai 201108
China
Phone: +86 21 3463 5025
Fax: +86 21 3463 5026
E-Mail: shanghai@schaefer.biz



VISIT US AT

WWW.SCHAEFER.BIZ

